

## 285 GALLON SINGLE WALL OVERHEAD STORAGE TANK

Item ID: TK-H-AG-SW-PL-OH-285

- ♦ All carbon steel construction for durable, safe, long-lasting liquid storage
- ♦ Constructed and air pressure tested for leaks in accordance with the UL-142 Standard for Steel Aboveground Tanks for Flammable and Combustible Liquids, Ninth Edition
- ♦ Gravity Feed Supply System eliminates the need for a pump
- ♦ Compatible with a wide range of fuels and chemicals
- ♦ Widely used in the Agricultural Industry
- ♦ Multiple finish coatings available
- ♦ Shown in optional Gateway Bronze finish



### SPECIFICATIONS

<b>Orientation:</b>	Horizontal
<b>Shell Dimensions:</b>	3'-2" x 5'-0"
<b>Material:</b>	Carbon Steel
<b>Shell Thickness:</b>	12 Gauge
<b>Head Thickness:</b>	12 Gauge
<b>Tank Support:</b>	A-Frame Assembly
<b>Area Inside Tank:</b>	39.38 cu. ft.

<b>Weight Empty:</b>	377 lbs.
<b>Labeling:</b>	Manufacturer's Label Only
<b>Operating Pressure:</b>	Atmospheric
<b>Test Method:</b>	Air Tested with Water and Soap Solution
<b>Interior Prep:</b>	Mill Finish
<b>Exterior Coating:</b>	Blast & Apply One Coat Red Oxide Primer

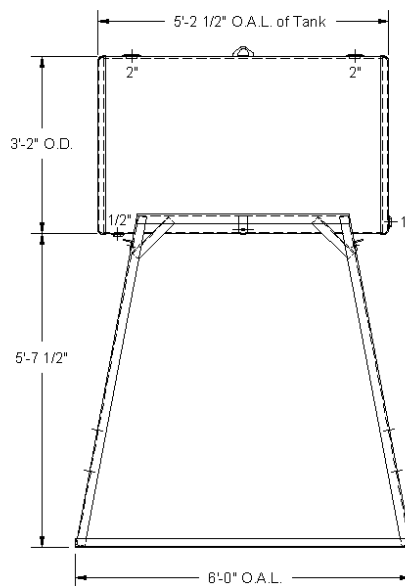

FRONT VIEW

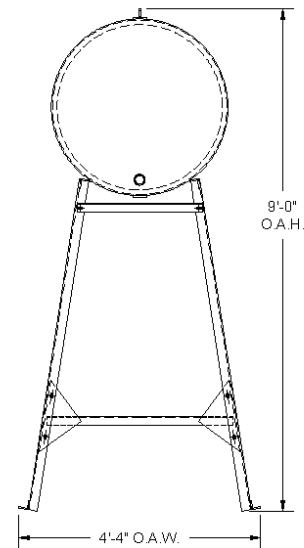

RIGHT END VIEW

#### HAMILTON TANKS, LLC

2200 Refugee Road, Columbus, OH 43207

Ph: (800) 627-8265 Fx: (614) 445-7248

www.hamiltontanks.com