

550 GALLON SINGLE WALL U.L. SKID TANK

Item ID: TK-H-AG-SW-UL-550

- ◆ All carbon steel construction for durable, safe, long-lasting liquid storage
- ◆ Constructed and air pressure tested for leaks in accordance with the UL-142 Standard for Steel Aboveground Tanks for Flammable and Combustible Liquids, Ninth Edition
- ◆ Support designs for all seismic zones
- ◆ Compatible with a wide range of fuels and chemicals
- ◆ Built with strict third-party quality control inspection program
- ◆ Customized compartments can be provided for cost effective multi-product storage
- ◆ Multiple finish coatings available



SPECIFICATIONS

Orientation:	Horizontal	Labeling:	U.L. 142
Shell Dimensions:	4'-0" x 6'-0"	Operating Pressure:	Atmospheric
Material:	Carbon Steel	Test Method:	Air Tested with Water and Soap Solution
Shell Thickness:	12 Gauge	Venting Capacity:	80,300 cu. ft./hr
Head Thickness:	12 Gauge	Interior Prep:	Remove Weld Slag & Vacuum
Tank Support:	U.L. Approved Angle Skid Assembly	Exterior Coating:	Blast & Apply One Coat Red Oxide Primer
Area Inside Tank:	75.40 cu. ft.		
Weight Empty:	560 lbs.		

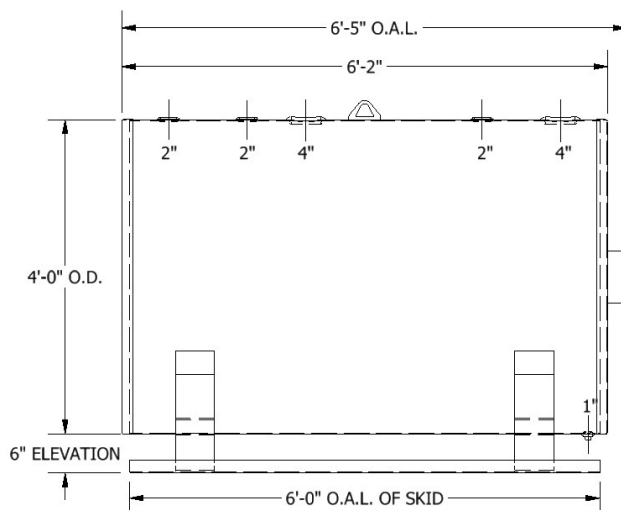

FRONT VIEW

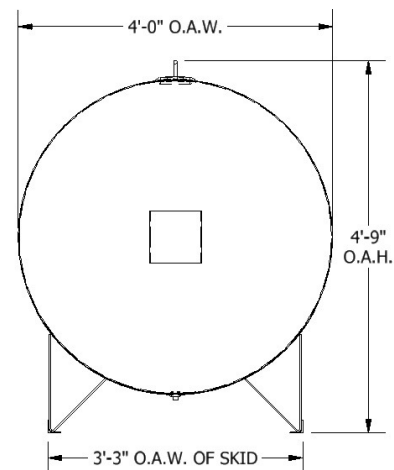

RIGHT END VIEW

HAMILTON TANKS, LLC

2200 Refugee Road, Columbus, OH 43207

Ph: (800) 627-8265 Fx: (614) 445-7248

www.hamiltontanks.com