

## 266 GALLON SINGLE WALL U.L. LUBE TANK

Item ID: TK-V-AG-SW-UL-275-LUBE

- ◆ All carbon steel construction for durable, safe, long-lasting liquid storage
- ◆ Constructed and air pressure tested for leaks in accordance with the UL-80 Standard for Steel Tanks for Lubes, Oils and other Combustible Liquids, Twelfth Edition
- ◆ Compatible with a wide range of fuels and chemicals
- ◆ Built with heavy duty forklift frame
- ◆ Comes complete with Oil Pump, Reel, Hose, Regulator, Filter, Control Handle, Gauge and Fill Cap



### SPECIFICATIONS

<b>Orientation:</b>	Vertical	<b>Weight Empty:</b>	450 lbs.
<b>Shell Dimensions:</b>	2'-3"W x 3'-8"H x 5'-0"L	<b>Labeling:</b>	U.L. 80
<b>Material:</b>	Carbon Steel	<b>Operating Pressure:</b>	Atmospheric
<b>Shell Thickness:</b>	12 Gauge	<b>Test Method:</b>	Air Tested with Water and Soap Solution
<b>Head Thickness:</b>	12 Gauge	<b>Interior Prep:</b>	Remove Weld Slag & Vacuum
<b>Tank Support:</b>	Skid Beam	<b>Exterior Coating:</b>	Blast & Apply One Coat Gray Enamel
<b>Area Inside Tank:</b>	35.82 cu. ft.		

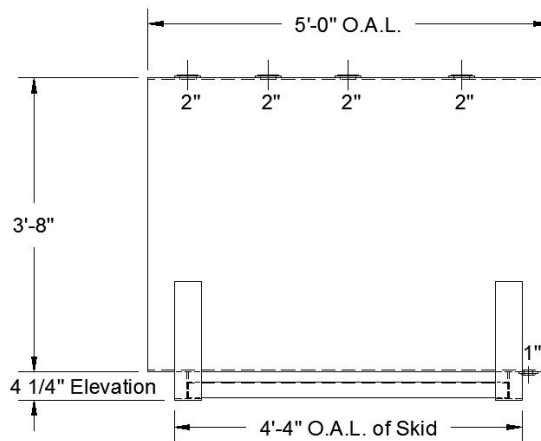

FRONT VIEW

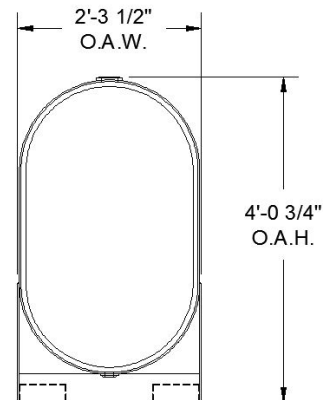

RIGHT END VIEW

#### HAMILTON TANKS, LLC

2200 Refugee Road, Columbus, OH 43207

Ph: (800) 627-8265 Fx: (614) 445-7248

www.hamiltontanks.com